



2011 NISSAN
FRONTIER



IT'S A WHOLE NEW WAY TO MOVE.

Find full-size attitude in the mid-size Frontier®. With 261 HP and 4.0 L of muscle, you've got up to 6500 lbs. (2949 kg) of towing capacity.^{1,2} A fully boxed ladder frame teamed up with advanced off-road technology means you're virtually unstoppable. With Crew Cab Long Bed (shown above), you've got room for five and a bed over 1860 mm (6 feet) long. And with either King Cab or Crew Cab, you've got room to stretch out. Big where you want it, nimble and efficient where you need it, it's a whole new way to move through the world. And you're invited.

¹Trailer brakes recommended for towing over 454 kg (1000 lbs.). Weight distribution hitch should be used for towing over 907 kg (2000 lbs.). See your Owner's Manual for complete details. ²Cargo and load capacity limited by weight and distribution. Properly secure cargo in bed of truck.



Nissan Frontier SL Crew Cab shown in Ink Blue.

Always pulling for you.

Performance – either you've got it, or you don't. And with Frontier, you've got it in a big way. With 4.0-L and 261 horsepower, you won't find a more powerful V6 in its class¹. And with a massive 281 lb-ft of torque, you can tow or haul just about anything you need to bring along. Maybe it's because we're a company that loves to compete – off-road, on the race-track, even in the showroom. But wherever we win, we're happy to share the prize with you.



261

horsepower

281

lb-ft of torque

6500

lbs.

(2949 kg) max towing²

A V6 that's pure muscle. With a colossal 261 horsepower and 281 lb-ft of torque, you won't find a more powerful V6 in a mid-size truck.

Rocket science. The 24-valve 4.0-L V6 works its magic with advanced technology, including a lightweight aluminum engine block, advanced valve timing system, variable intake and race-bred friction-reducing technology.

PRO-4X OFF ROAD

The ultimate off-road Frontier, the PRO-4X. Exhibit championship form with the ultimate gear, including Bilstein® off-road performance shocks, an electronic locking rear differential, 4-wheel Active Brake Limited Slip (ABLS), skid plates and 265/75R16 BFGoodrich® Rugged Trail T/A® tires. Add in unique 16" 6-spoke alloy wheels, halogen fog lights and an exclusive 2-tone interior, and you've got a winning combination, inside and out.



Nissan Frontier SV King Cab 4x2 shown in Silver Mist.
U.S. model shown without standard splash guards.

A 4-cylinder that feels like a 6. Frontier also offers a 2.5-L 4-cylinder that pumps out 152 horsepower, 171 lb-ft of torque and features a compact balancer system to deliver the smoothness of a V6.

Gear up. You can harness the 4-cylinder's power through a 5-speed manual transmission or an available 5-speed automatic. The V6 is available with either a 6-speed manual or 5-speed automatic transmission.



Nissan Frontier PRO-4X King Cab shown in Matador Red.

Electronic locking differential. When 4x4 mode just isn't enough, flip the switch to activate the electronic locking rear differential. This ultimate off-road feature delivers equal power to both rear wheels to boost traction and help keep your truck moving forward. When engaged, it works in conjunction with the 4-wheel Active Brake Limited Slip (ABLS). So while the locking rear differential keeps the rear wheels powered to move you ahead, ABLS gives you the traction you need up front to help maintain steering control.

Hill start assist. When starting on steep hills from a stop, hill start assist will help keep you from rolling backwards. It holds brake pressure for a few seconds, allowing you enough time to switch from the brake pedal to the accelerator.³

Hill descent control. When driving down a steep grade in 4WD and engine braking isn't enough, hill descent control can help. Just flip the switch, ease your foot from the accelerator, and this system automatically maintains speed and brake pressure to help provide a controlled descent.³

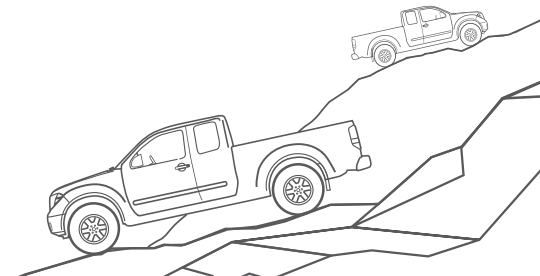

Shows real backbone with a fully boxed frame.



FULLY BOXED FRAME



CONVENTIONAL C-RAIL

- ① Overslung rigid leaf-spring rear suspension
- ② Available heavy-duty Dana® rear axle
- ③ 4-wheel vented disc brakes with Anti-lock Braking System (ABS)
- ④ Steel double-wishbone front suspension

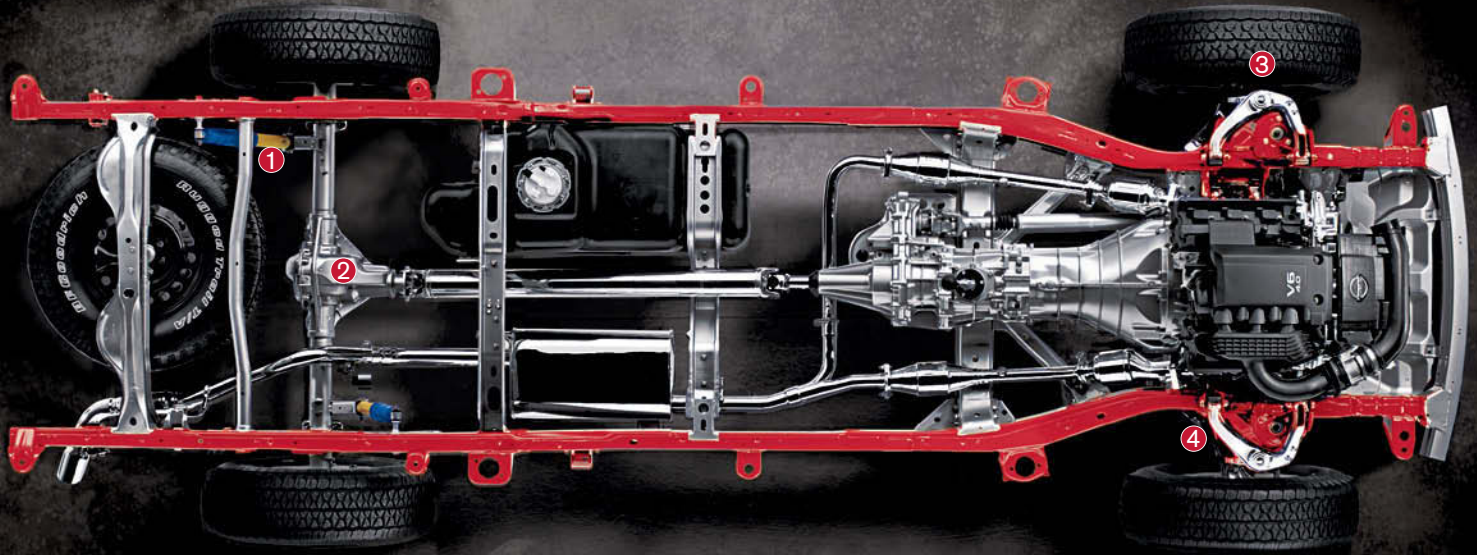

Brainpower meets brawn-power. Off-road you have to be tough, so Frontier starts with a rigid fully boxed frame, underbody components tucked up above frame level and shift-on-the-fly up to 100 km/h (62 mph). But it also pays to be smart, so Frontier also features state-of-the-art advanced off-road technologies, including VDC¹ and 4-wheel Active Brake Limited Slip (ABLS)². They're so intelligent, they also make the Frontier a more confident and responsive vehicle when you decide to do some occasional on-riding.

Anti-lock Braking System (ABS) rapidly pumps the brakes during hard braking to help keep your wheels from locking up, thus helping you to steer around an obstacle.

Electronic Brake force Distribution (EBD) senses additional weight, whether it's a full cargo bed or a full tank of gas, and sends extra force to the rear brakes.

Vehicle Dynamic Control (VDC)¹ Also known as electronic stability control, VDC monitors driver inputs and vehicle motion and helps compensate for oversteer or understeer to help keep you on your steered path.

Active Brake Limited Slip (ABLS)² To help keep your wheels from spinning, Frontier offers ABLS, a system that senses when a wheel begins to slip, then automatically brakes the slipping wheel (or wheels) and sends additional power to the wheels with the best traction².

Puts your cargo in lockdown.

The Utili-track™ Channel System on Frontier gives you choices few other trucks can match. No matter what type of cargo you're carrying, this available system is fully equipped to help keep it secured tightly. Five channels, four cleats and a lot of thought about how people really use their trucks have created a system that's simple, rugged and offers near-infinite possibilities.



4 CLEATS

Frontier has four **heavy-duty forged aluminum cleats** that easily slide in the channels for unmatched flexibility to tie things down – and the strength to hold them.



5 CHANNELS

Unmatched versatility comes in the form of five channels – including two channels in the floor, a feature few competitors can match. Frontier makes sure you find the right place to secure whatever you bring along.

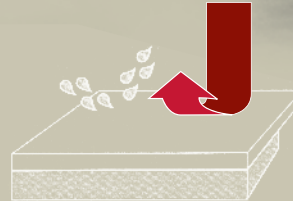

SPRAY-ON BEDLINER

The available **spray-on bedliner** adds to the incredible versatility of the bed. It's applied at the factory – so you know it's done right. Fade- and weather-resistant, it's a rugged, non-skid surface that adheres directly to the bed to help prevent rusting.



Loads of accessories There's also a full line of accessories to help you get even more out of Utili-track™, including a sliding tool box, a sliding bed divider and a sliding bed extender.



Frontier Crew Cab.

Inside or out, Frontier Crew Cab has the space you need. Outside, Frontier Crew Cab offers two available bed lengths: 1861 mm (73.3") or 1511 mm (59.5"). Inside, space and comfort are as abundant as fresh air. Real-size doors make for easy entry, while a 60/40 rear bench allows seating for five and folds easily to create a large, flat surface. Or you can flip up the rear seat cushions for more storage room. An under-seat storage tray is removable for even greater flexibility.

FOLDS FLAT

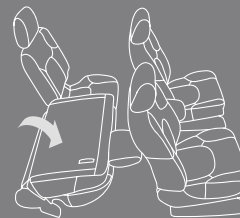

FLIPS UP

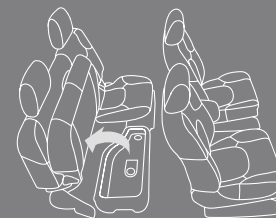

Nissan Frontier SL Crew Cab shown in Steel Leather.

¹Available feature. See Specifications section for details. ²Please keep in mind that airbags are a supplemental restraint system and must always be used in conjunction with a seat belt. Even with the occupant-classification sensor, a rear-facing child restraint should not be placed in the front-passenger's seat. Also, in addition to any other requirement of applicable law, all children 12 and under should ride in the rear seat properly secured in child

Frontier King Cab.

Open for anything. Frontier King Cab has rear doors that give your passengers easy access to the cabin. And with no B-pillars, you also get a huge opening for larger-than-life items. The two rear seats face forward, or flip up and out of the way to reveal a large open space for cargo. The front-passenger seat also folds down¹ to carry larger items or to make a flat surface for writing cheques other trucks can't cash. And with storage options, including a removable storage tray under the rear seats, your gear is out of sight and safe from prying eyes.



Nissan Frontier PRO-4X King Cab shown in Graphite Red Cloth.

Safety. First and foremost. The Nissan Safety Shield is our comprehensive approach to safety. It includes rigorous crash testing, over 50 standard safety features on every vehicle, advanced technologies and child-safety programs like Snug Kids. In Frontier, a standard Advanced Airbag System featuring seat-mounted side-impact supplemental airbags and roof-mounted curtain side-impact supplemental airbags are all confidence-inspiring examples of our safety philosophy in action.²



U.S. instrumentation shown.

Designed for advanced civilization.

It's all within reach. You see a great-looking interior. We see attention to detail that makes Frontier exceptionally easy to live with. Find a perfect position with an available 8-way power adjustable driver's seat. At your fingertips, a grippy leather-wrapped steering wheel with controls to operate the cruise control and audio – all the better to crank up the available Rockford Fosgate-powered audio system. Heating and ventilation controls are big and easy to operate – even with gloves on. No detail is overlooked. You track your progress with big, quickly read gauges that display all the essentials – there's even an indicator light if tire pressure is low.



Your tunes sound better through an available 10-speaker Rockford Fosgate-powered audio system, including XM[®] Satellite Radio¹.



Your music is fingertip-close with the available Genuine Nissan Accessory iPod[®] Interface System that lets you control your iPod[®] through the audio system's controls.²



Bluetooth[®] Hands-Free Phone System lets you make and take calls with your hands on the wheel and listen to calls through the audio system's speakers.³

¹XM[®] Satellite Radio is available in the 10 Canadian provinces and the 48 contiguous United States. Basic monthly subscription required and sold separately after trial period. Subscription subject to terms and conditions at xmradio.ca. All fees and programming subject to change. © 2010 XM Satellite Radio Inc. The XM name and related logos are registered trademarks of XM Satellite Radio Inc. All other trademarks are the property of their respective owners. ²Always give your full attention to driving. Avoid operating your iPod in such a way that you can be distracted during vehicle operation. See Dealer for details. ³iPod is a registered trademark of Apple Inc.

Trim Levels

Frontier King Cab



S

Features 152 HP 2.5-litre 4-cylinder engine mated to a 5-speed manual or a 5-speed automatic, engine block heater, 4-wheel disc brakes with ABS, rear access doors, black front bumper and chrome rear bumper, front and rear splash guards, sliding rear window, privacy glass, fold-flat front passenger seat, forward-facing rear flip-up seats, AM/FM/CD audio system, air conditioning, Tire Pressure Monitoring System (TPMS),⁴ tilt steering wheel, floor mats, power windows and locks, power heated outside mirrors, cruise control, remote keyless entry, anti-theft system and Immobilizer Key System and 6 standard airbags.

This trim level is available in 4x2 only.

Frontier Crew Cab



SV

Adds to S: 261 HP 4.0-litre V6 engine with a 6-speed manual transmission or a 5-speed automatic transmission, 2-wheel or 4-wheel Active Brake Limited Slip (ABLS), 16" aluminum-alloy wheels, front tow hook, chrome front bumper and Vehicle Dynamic Control (VDC). 4x4 automatic transmission models also include hill descent control and hill start assist.

Crew Cab adds: High Utility Bed (Utili-track™ Channel System with 4 tie-down cleats, factory-applied spray-on bedliner and bed rail caps) and rear window defroster.



SV



PRO-4X

Adds to SV: PRO-4X Bilstein® shocks, electronic locking rear differential, skid plates, P265/75R16 BFGoodrich® Rugged Trail T/A® OWL tires, 16" aluminum-alloy off-road wheels, High Utility Bed, fog lights, body-colour front and rear bumpers, grille, door handles and outside mirrors, Bluetooth® Hands-Free Phone System,³ mid-grade audio system with 6-CD changer with MP3/WMA playback capability, XM® Satellite Radio¹ (automatic transmission only), auxiliary audio input jack and steering-wheel-mounted audio controls, auto-dimming rearview mirror, digital compass and outside temperature display.

Crew Cab adds: Roof rack with crossbars, power sliding glass moonroof and Rockford Fosgate-powered audio system.

This trim level is available in 4x4 only.



PRO-4X

Adds to SV: 5-speed automatic transmission, P265/60R18 BFGoodrich® Radial Long Trail T/A® tires, 18" aluminum-alloy wheels, fog lights, roof rack with crossbars, tubular step rails, power sliding glass moonroof, chrome door handles and outside mirrors, 8-way power adjustable driver's seat, 4-way power adjustable passenger's seat, leather seating surfaces, heated front seats, leather-wrapped steering wheel, Bluetooth® Hands-Free Phone System,³ Rockford Fosgate-powered audio system with AM/FM/in-dash 6-CD changer, MP3/WMA playback capability and XM® Satellite Radio.¹

This trim level is available in 4x4 only.



SL

Features & Specifications

Engine	S KC 4x2	SV KC/CC 4x2/4x4	PRO-4X KC/CC 4x4	SL CC 4x4
QR25DE – 2.5-litre DOHC 16-valve 4-cylinder engine				
— Horsepower – 152 HP @ 5200 rpm				
— Torque – 171 lb-ft @ 4400 rpm				
VQ40DE – 4.0-litre DOHC 24-valve V6 engine				
— Horsepower – 261 HP @ 5600 rpm				
— Torque – 281 lb-ft @ 4000 rpm				
Emissions – LEV2 ULEV				
Continuously Variable Valve Timing Control System (CVTCS)				
Variable Intake System				
Nissan Direct Ignition System with platinum-tipped spark plugs				
Engine block heater				

Drivetrain	S KC 4x2	SV KC/CC 4x2/4x4	PRO-4X KC/CC 4x4	SL CC 4x4
5-speed manual transmission				
6-speed manual transmission (4x4)			1	
5-speed automatic transmission (4x2)	□	1		
5-speed automatic transmission (4x4)		□	1 2	
Dana® 44 rear axle		3		
Switch-operated 2-speed transfer case (4x4 models only)				
Electronic locking rear differential				
2-wheel Active Brake Limited Slip (ABLS) (4x2 models only)				
4-wheel Active Brake Limited Slip (ABLS) (4x4 models only)				
Vehicle Dynamic Control (VDC)				
Hill descent control and hill start assist		4	4	

Wheels/Tires	S KC 4x2	SV KC/CC 4x2/4x4	PRO-4X KC/CC 4x4	SL CC 4x4
15" x 7" 6-spoke steel wheels				
16" x 7" 6-spoke steel wheels	AP			
16" x 7" 5-spoke aluminum-alloy wheels				
16" x 7" 6-spoke machined-finish aluminum-alloy wheels				
18" x 7.5" 12-spoke machined-finish aluminum-alloy wheels				
P235/75R15 General Grabber™ all-season tires				
P265/70R16 BFGoodrich® Long Trail T/A® OWL tires	AP			
P265/75R16 BFGoodrich® Rugged Trail T/A® OWL tires				
P265/60R18 BFGoodrich® Long Trail T/A® tires				
Full-size spare tire				
Tire Pressure Monitoring System (TPMS)				

Brakes	S KC 4x2	SV KC/CC 4x2/4x4	PRO-4X KC/CC 4x4	SL CC 4x4
4-wheel vented disc brakes				
4-wheel Anti-lock Braking System (ABS)				
Electronic Brake force Distribution (EBD)				

Suspension/Steering	S KC 4x2	SV KC/CC 4x2/4x4	PRO-4X KC/CC 4x4	SL CC 4x4
Front: Independent double-wishbone				
Rear: Overslung multi-leaf with solid axle				
PRO-4X Bilstein® off-road performance shock absorbers				
Front stabilizer bar				
Engine-speed-sensitive power-assisted rack-and-pinion steering				

Exterior	S KC 4x2	SV KC/CC 4x2/4x4	PRO-4X KC/CC 4x4	SL CC 4x4
Standard Bed – 1511 mm (59.5")			2	
Long Bed – 1861 mm (73.3")			1	
Skid plates (oil pan, fuel tank, 4x4 transfer case)				
Automatic on/off headlights				
Fog lights				
Roof rack with crossbars			2	
Step rails				
Front tow hook				
Splash guards				
Upper body-colour/lower black front bumper				
Chrome front bumper	AP			

Exterior (continued)	S KC 4x2	SV KC/CC 4x2/4x4	PRO-4X KC/CC 4x4	SL CC 4x4
Chrome grille				
Chrome rear bumper				
Body-colour front and rear bumper, grille, door handles — and outside mirrors				
Black door handles and mirrors				
Chrome door handles and outside mirrors				
Dual heated power outside mirrors and rear privacy glass				
Body-colour side mouldings				
Utili-track™ Channel System with 4 tie-down cleats		2		
Factory-applied spray-on bedliner and bed rail caps		2		
Locking tailgate and cargo bed light				
Power sliding glass moonroof with one-touch open/close			2	
Sliding rear window		1	1	
Rear defroster		2	2	

Audio	S KC 4x2	SV KC/CC 4x2/4x4	PRO-4X KC/CC 4x4	SL CC 4x4
AM/FM/CD audio system				
AM/FM/in-dash 6-CD audio system			1	
Rockford Fosgate-powered audio system — with AM/FM/in-dash 6-CD changer (380 watts)			2	
Steering-wheel-mounted audio controls				
Auxiliary audio input jack, Radio Data System (RDS) and — MP3/WMA capability				
4 speakers		1		
6 speakers		2	1	
10 speakers, including subwoofers			2	
XM® Satellite Radio ⁵			4	

Interior	S KC 4x2	SV KC/CC 4x2/4x4	PRO-4X KC/CC 4x4	SL CC 4x4
Air conditioning				
Bluetooth® Hands-Free Phone System				
Power door locks with auto-locking feature				
Power windows with driver one-touch auto-down				
Remote keyless entry				
HomeLink® universal garage-door opener				
Cruise control				
Variable intermittent windshield wipers				
Auto-dimming rearview mirror, digital compass and outside — temperature display				
Front map lights, voltage and oil pressure gauges				
Two 12-volt DC power outlets				
Multi-functional trip computer				
Dual sunvisors with extenders, dual visor vanity — mirrors (illuminated on SL) and tilt steering column				
First-aid kit				

Seating/Appointments	S KC 4x2	SV KC/CC 4x2/4x4	PRO-4X KC/CC 4x4	SL CC 4x4
8-way manual driver's seat with adjustable lumbar				
8-way power adjustable driver's seat			L	
4-way power adjustable passenger's seat			L	
Heated front seats			L	
Fold-flat front-passenger's seat (N/A with leather)				
Forward-facing rear flip-up seats		1	1	
60/40 split flip-up rear bench seat		2	2	
Cloth seat trim				
PRO-4X cloth seat trim and manual transmission gear shifter — with red stitching				
Leather seating surfaces				
PRO-4X embroidered leather seating surfaces			L	
Leather-wrapped steering wheel				

Seating/Appointments (continued)	S KC 4x2	SV KC/CC 4x2/4x4	PRO-4X KC/CC 4x4	SL CC 4x4
Second-row under-seat storage	■	■	■	■
Driver's seatback pocket		²	■	■
Rear seat centre armrest			□	■
White-face gauges			■	
Four cup holders and front and rear door storage pockets	■	■	■	■
Overhead sunglasses storage		²	■	■

Safety/Security	S KC 4x2	SV KC/CC 4x2/4x4	PRO-4X KC/CC 4x4	SL CC 4x4
Nissan Advanced Airbag System (AABS) with dual-stage				
— supplemental front airbags with seat belt and				
— occupant-classification sensors	■	■	■	■
Driver and front passenger seat-mounted side-impact				
— supplemental airbags	■	■	■	■
Roof-mounted curtain supplemental airbags for				
— side-impact and rollover protection for outboard occupants	■	■	■	■
3-point ALR/ELR passenger seat belt system (ELR for driver)	■	■	■	■
Front-seat Active Head Restraints	■	■	■	■
Front seat belts with pre-tensioners and load limiters	■	■	■	■
LATCH System (Lower Anchors and Tethers for CHildren)	■	■	■	■
Zone Body construction with front and rear crumple zones	■	■	■	■
Hood-buckling creases and energy-absorbing steering column	■	■	■	■
Pipe-style steel side-door guard beams	■	■	■	■
Anti-theft system and Immobilizer Key System	■	■	■	■

Packages

AP S Appearance Package

- 16" 6-spoke steel wheels
- P265/70R16 BFGoodrich® Long Trail T/A® OWL tires
- Chrome front bumper

□ PRO-4X Leather Package (Crew Cab only)

- Leather seating surfaces
- 8-way power adjustable driver's seat
- 4-way power adjustable passenger's seat
- Heated front seats
- Rear seat centre armrest

Dimensions/Capacities

Exterior Dimensions – mm (inches)			
	KING CAB REGULAR		CREW CAB REGULAR/LONG BED
Wheelbase	3200 (125.9)		3200 (125.9)/3554 (139.9)
Overall length	5220 (205.5)		5220 (205.5)/5574 (219.4)
Overall width	1850 (72.8)		1850 (72.8)
Overall height	1745–1770 (68.7–69.7)		1780–1879 (70.1–73.9)
Track width	1570 (61.8)		1570 (61.8)
Bed length	1861 (73.3)		1511 (59.5)/1861 (73.3)
Bed width	1560 (61.4)		1560 (61.4)
Bed depth	457 (18.0)		457 (18.0)

Interior Dimensions – mm (inches)			
	KING CAB		CREW CAB
Head room	(front/rear)	1010/973 (39.7/38.3)	1017/983 (40.0/38.7)
Leg room	(front/rear)	1076/644 (42.4/25.4)	1076/854 (42.4/33.6)
Hip room	(front/rear)	1416/1396 (55.8/55.0)	1412/1473 (55.6/58.0)
Shoulder room	(front/rear)	1480/1394 (58.3/54.9)	1480/1481 (58.3/58.3)

Curb Weights – kg (lbs)				
KING CAB	S	SV	PRO-4X	SL
Manual transmission (4x2)	1683 (3703)	–	–	–
Manual transmission (4x4)	–	1943 (4274)	1985 (4365)	–
Automatic transmission (4x2)	1691 (3721)	1873 (4120)	–	–
Automatic transmission (4x4)	–	1950 (4289)	1968 (4381)	–
CREW CAB				
Automatic transmission (4x2)	–	1970 (4335)	–	–
Automatic transmission (4x4)	–	2068 (4550)	2067 (4548)	2121 (4667)

Maximum Payload – kg (lbs)				
KING CAB	S	SV	PRO-4X	SL
Manual transmission (4x2)	439 (965)	–	–	–
Manual transmission (4x4)	–	636 (1399)	553 (1216)	–
Automatic transmission (4x2)	436 (958)	660 (1452)	–	–
Automatic transmission (4x4)	–	629 (1383)	546 (1201)	–
CREW CAB				
Automatic transmission (4x2)	–	626 (1377)	–	–
Automatic transmission (4x4)	–	567 (1248)	470 (1034)	511 (1123)

Maximum Towing Capabilities – kg (lbs)				
		KING CAB	CREW CAB	
4x2	4-cylinder	1588 (3500)	–	
	V6	2949 (6500)	2858 (6300)	
4x4	V6	2858 (6300)	2767 (6100)	

Off-road Capabilities			
	KING CAB	CREW CAB	
Minimum running ground clearance – mm (inches)	193–226 (7.6–8.9)	218–226 (8.6–8.9)	
Angle of approach; V6 models – 4x2 (4x4)	30.5° (32.6°)	30.5° (32.6°)	
Angle of departure; V6 models – 4x2 (4x4)	22.1° (23.3°)	22.1° (23.3°)	
Ramp over angle	19.5° – 20.6°	19.0° – 20.6°	

Capacities			
		KING CAB	CREW CAB
Interior passenger volume – L (cu. ft.)		2483 (87.7)	2863 (101.1)
Fuel tank – L (Imp gal)		80 (18)	80 (18)

2011 Fuel Consumption Estimates – L/100 km (mpg)			
4x2/4x4		4-CYL.	V6
Manual transmission	City	10.7 (26)	–/13.8 (20)
	Hwy	8.6 (33)	–/10.4 (27)
Automatic transmission	City	12.5 (23)	14.2 (20)/14.8 (19)
	Hwy	9.1 (31)	9.8 (29)/10.4 (27)

— Actual mileage may vary with driving conditions – use for comparison only.

- Standard
- Optional
- AP Part of S Appearance Package
- Part of PRO-4X Leather Package

¹King Cab only. ²Crew Cab only. ³Manual transmission only. ⁴Automatic transmission only. ⁵XM® Satellite Radio is available in the 10 Canadian provinces and the 48 contiguous United States. Basic monthly subscription required and sold separately after trial period. Subscription subject to terms and conditions at xmradio.ca. All fees and programming subject to change. © 2010 XM Satellite Radio Inc. The XM name and related logos are registered trademarks of XM Satellite Radio Inc. All other trademarks are the property of their respective owners. ⁶Dana is a registered trademark of Dana Corporation. ⁷HomeLink is a registered trademark of Johnson Controls Technology Company. ⁸Bilstein is a registered trademark of ThyssenKrupp Bilstein GmbH. ⁹BFGoodrich is a registered trademark of Goodrich Corporation. TMGeneral Grabber is a trademark of General Tire and Rubber Company. [®]The Bluetooth word mark and logos are owned by Bluetooth SIG, Inc., and any use of such marks by Nissan is under licence. [®]Long Trail T/A and Rugged Trail T/A are registered trademarks of Uniroyal Goodrich Licensing Services, Inc.

Paint and Fabric Selections



Knight Armour¹	K26	S ²	SV V6	PRO-4X	SL
Steel Cloth			■ ³		
Steel Leather					■ ³
Beige Cloth			■		
Beige Leather					■ ³
Graphite Cloth		■ ²			
Graphite Red Cloth				■	
Graphite Leather				■ ³	



Ebony	KH3	S ²	SV V6	PRO-4X	SL
Steel Cloth			■ ³		
Steel Leather					■ ³
Beige Cloth			■		
Beige Leather					■ ³
Graphite Cloth		■	■ ²		
Graphite Red Cloth				■	
Graphite Leather				■ ³	



Arctic White	QM1	S ²	SV V6	PRO-4X	SL
Steel Cloth			■ ³		
Steel Leather					■ ³
Beige Cloth			■		
Beige Leather					■ ³
Graphite Red Cloth				■	
Graphite Leather				■ ³	



Silver Mist¹	K12	S ²	SV V6	PRO-4X	SL
Steel Cloth		■	■ ³		
Steel Leather					■ ³
Graphite Cloth		■	■ ²		
Graphite Red Cloth				■	
Graphite Leather				■ ³	



Matador Red	A20	S ²	SV V6	PRO-4X	SL
Steel Cloth			■ ³		
Graphite Cloth			■ ²		
Graphite Red Cloth				■	
Graphite Leather				■ ³	



Ink Blue¹	RAB	S ²	SV V6	PRO-4X	SL
Steel Cloth			■ ³		
Steel Leather					■ ³
Beige Cloth			■		
Beige Leather					■ ³
Graphite Cloth			■ ²		
Graphite Red Cloth				■	
Graphite Leather				■ ³	



Carmine¹	NAC	S ²	SV V6	PRO-4X	SL
Beige Cloth			■		
Beige Leather					■ ³
Graphite Cloth		■			

S
Steel Cloth²

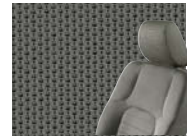

S
Graphite Cloth²



SV
Graphite Cloth²



SV
Beige Cloth²



SV
Steel Cloth³



SV
Beige Cloth³



PRO-4X
Graphite Red Cloth



PRO-4X
Graphite Leather³

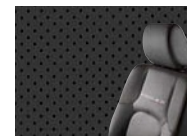

SL
Steel Leather³



SL
Beige Leather³



■ Standard.

■ Part of Leather Package

¹ Extra cost option

² King Cab only

³ Crew Cab only

Nissan has taken care to ensure that the colour swatches presented here are the closest possible representations of actual vehicle colours. Swatches may vary slightly due to the printing process and whether viewed in daylight, fluorescent or incandescent light. Please see your local Nissan Dealership for actual colours and pricing information.

Genuine Nissan Accessories

Every Genuine Nissan Accessory is custom-fit, custom-designed and durability-tested. Each one is backed by Nissan's 1 year/20,000 km Parts and Accessories limited warranty.⁴ Plus, they're just a few dollars a month when financed with vehicle purchase. See your Nissan dealer for more information on Frontier accessories or log on to accessories.nissan.ca

Floor Liner



Towing Equipment



Side-window Deflector



Commitment

From the moment you first think about a Nissan to the time you actually drive off the lot and long beyond, we want every experience to be special. Passionate. Exhilarating. Like the vehicles we design and build. After all, what's excitement without commitment?

Continue your excitement at nissan.ca You'll find virtual product demonstrations, a way to "build your own Nissan," a dealer locator, and more information about key Nissan support and services.

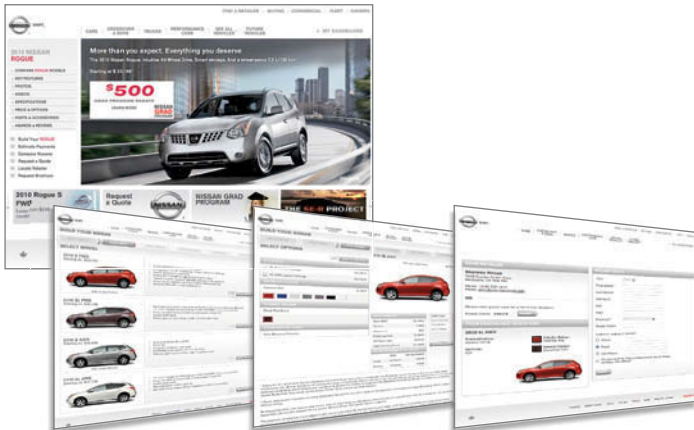

Choose your model

Select colours

Request a quote

Finance Options Through Nissan Canada Finance, we offer many attractive purchase and lease programs, all with competitive rates and terms. With our flexible finance options, driving home a new Nissan has never been easier. Consult your local Nissan Dealership for complete details.

No-Nonsense Warranty Every 2011 Nissan is covered by a 3 year/60,000 km⁵ Comprehensive New Vehicle Warranty, a 5 year/100,000 km⁵ Powertrain Warranty, an 8 year/130,000 km⁵ Emission Control Warranty on selected components, and a 5 year/unlimited km Corrosion Perforation Warranty. As a Nissan owner, you'll also receive a 3 year Roadside Assistance program available to you 24 hours a day.

Added Security Plan (ASP) For ultimate peace of mind, consider the Nissan Added Security Plan. It's our commitment to be there for you, and to help you leave your worries behind. Different plans, available for both purchased and leased vehicles, let you tailor the coverage to your driving habits.

Nissan's philosophy toward the environment, "Seeking a symbiosis of people, vehicles and nature," describes our ideal for a sustainable mobile society, now and in the future. We launched the Nissan Green Program with specific objectives to realize this goal, and we are pursuing it energetically.



⁴See your Nissan Dealership and read the actual limited warranty. ⁵Whichever comes first.

10 REASONS TO CHOOSE FRONTIER®



OF COURSE, NISSAN QUALITY ALWAYS COMES ALONG FOR THE RIDE.

An available V6 with a **powerful 261 HP** and stump-pulling 281 lb-ft of torque.

A **fully boxed, full-length ladder frame.** Heavy-duty to its core.

Up to **6500-lb. (2949 kg) maximum towing capacity.** Nothing gets left behind!

Utili-track™ Channel System. Puts even the most awkward loads on lockdown.

Crew Cab Long Bed. A 1861 mm (6' 1") bed with a big appetite for adventure.

PRO-4X model with electronic locking rear differential. It's virtually unstoppable.

Available Active Brake Limited Slip (ABLS). Explore with confidence.

An available Rockford Fosgate-powered audio system. 10 speakers, 6-CD changer. Rock on.

An available Bluetooth® Hands-Free Phone System. Never fumble for the phone again.²

Available auxiliary audio input jack for your iPod®. Just plug and play.³

visit www.nissan.ca

¹Trailer brakes recommended for towing over 454 kg (1000 lbs.). Weight distribution hitch should be used for towing over 907 kg (2000 lbs.). See your Owner's Manual for complete details. ²Availability of specific features is dependent upon the phone's Bluetooth® support. Please refer to your phone Owner's Manual for details. Cell phone not included. The Bluetooth word mark and logos are owned by Bluetooth SIG, Inc., and any use of such marks by Nissan is under licence. ³Driving is serious business and requires your full attention. Do not operate any devices connected to the USB or auxiliary audio input jack while driving. ⁴iPod is a registered trademark of Apple, Inc. All rights reserved. iPod not included.

All illustrations, photographs and specifications in this brochure are based on the latest product information. See actual vehicle for complete accuracy. Nissan Canada Inc. reserves the right to make changes at any time, without notice, in prices, colours, materials, equipment, specifications and models, and to discontinue models or equipment. For information on additional options and accessories, contact your Nissan Dealership. Registered trademarks are property of their respective owners. At www.nissan.ca, you'll find virtual product demonstrations, a way to "build your own Nissan," a dealer locator, and more information about key Nissan support services. The Nissan names, logos, product names, feature names, and slogans are trademarks owned by or licensed to Nissan Motor Co. Ltd. and/or its North American subsidiaries. **Always wear your seat belt, and please don't drink and drive.** Printed in September 2010. Catalogue number: 99999-FRN11EN. © 2010 Nissan Canada Inc. All rights reserved.



SHIFT the way you move